

The Oscillators manufactured by Transko can be classified into four categories:

1. Clock oscillator
2. VCXO
3. (VC) TCXO
4. (VC) OCXO

A basic process of manufacturing of crystal oscillators:
 A thin film metal-coated crystal is mounted on input and output terminal of the oscillator module during assembly. The crystal gets calibrated after mounting on the module. Then parts get sealed and do final test.

What is Frequency Stability?

When oscillators are made, the term “frequency stability” includes frequency change due to all causes:

1. Calibration
2. Operating temperature range
3. Shock
4. Vibration
5. Humidity
6. Input voltage
7. Aging
8. Load change

What is Logic Level?

A logic level is one of a finite number of states that a signal can have. Logic levels are usually represented by the voltage difference between the signal and ground (or some other common reference point), although other standards exist. The range of voltage levels that represents each state depends on the Logic family being used. Here is some oscillator’s logic families.

1. TTL
2. CMOS
3. HCMOS
4. LVDS
5. ECL
6. (LV) PECL

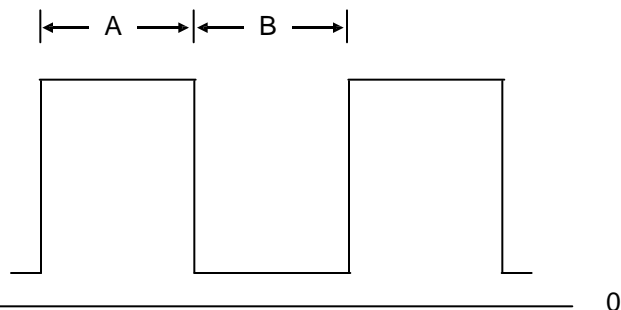

What is Symmetry?

The term symmetry relates to an on/off pulse relationship (measured at a specified voltage level)

Ideally, A and B are identical. The symmetry between the two is expressed in percentage. (Example; 50/50 = 50% on, 50% off; 60/40 = 60% on, 40% off)

What is Rise and Fall Time?

Rise time (T_r) defines the time required for the pulse to reach specified minimum, "1" level. Fall time (T_f) is the time needed to fall to specified maximum "0" level:

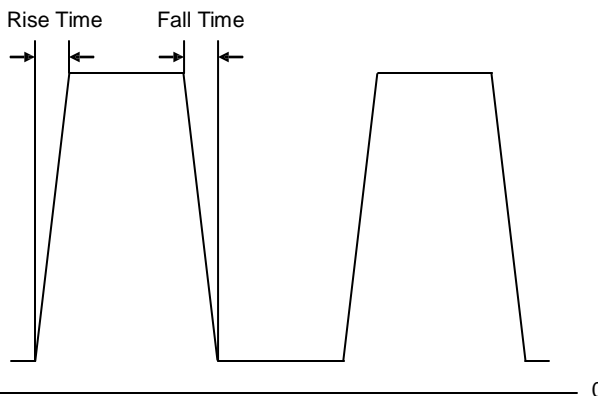

The ideal is a perfect square wave, but the wave is seldom perfect, so rise and fall time must be defined.

What is Fan Out?

This term defines the number of gate loads the oscillator will drive. The oscillator must have sufficient sink current capability, which must be capable of delivering enough current to supply a number of gate loads.

What is the difference between Enable/Disable vs. Tri-State mode?

The tri-state mode is similar to the Enable/Disable. When you have a “logic 1” on pin 1, the unit works same as normal “enabled” producing the specified output. When the pin 1 is “logic 0” it goes into high impedance or tri-state mode. The tri-state mode allows the customer to remove the oscillator from their circuit without physically removing it. It is useful for tuning, testing or trouble shooting their board. But disable mode has lower than its normal operating current but not completely cut off which means there is current floating. Therefore the control pin can be left open if unused.

What is Jitter?

Jitter is the time variation of a characteristic of a periodic signal. Jitter comes from many sources. Cycle to cycle jitter is the difference in time between adjacent cycles of the signal. The peak-to-peak period jitter is the worst case. Period jitter is the maximum change of a clock signal. The RMS period jitter is the standard deviation of the peak-to-peak period jitter. We approximate peak to peak as 7 times the RMS value. The period jitter can be measured at each cycle, not multiple cycles.

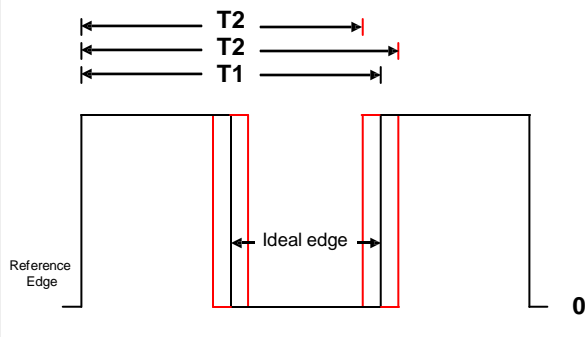

What is Start Up Time?

Start up time is the period of time from the voltages applied to the oscillator output is stabilized.

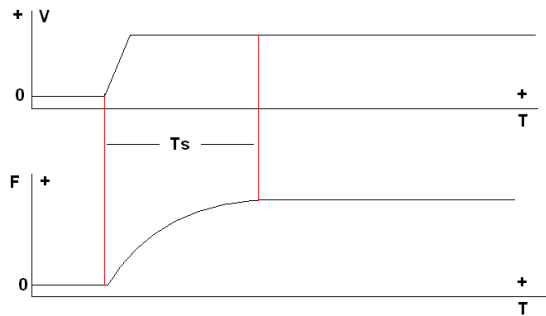

What is Phase Noise?

Phase noise is a measure of the short-term frequency instability of the oscillator. It is measured as the single sideband noise, resulting from changes in frequency, in decibels below the amplitude at the operating frequency of the oscillator using a 1 Hz bandwidth at two or more frequency displacements from the operating frequency of the oscillator.

Phase noise measurement equipment built by Transko (TPNA-2001A), which is a good fit for oscillators.

